

MT Push Hire Information

A few useful hints and tips to help you get the most out of your MT push:



THE ALL TERRAIN WHEELCHAIR

Transfer

FOLDING FOOTREST

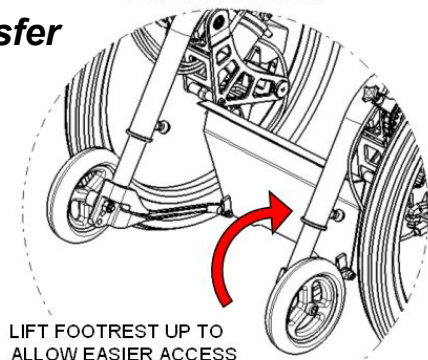

You may wish to move the armrests out of the way by lifting upwards and rotating rearwards

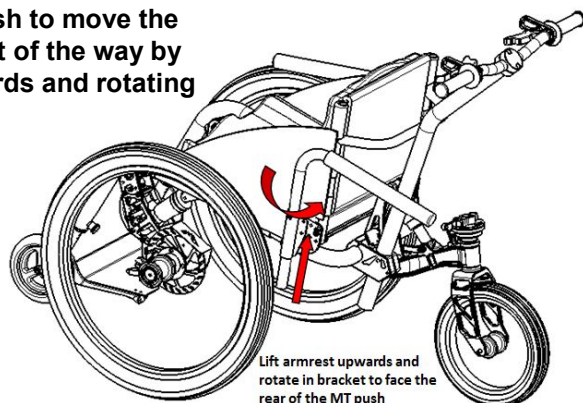

Do not stand on footrest during transfer. Lift the footplate up so it is out of the way, then fold down once seated

Parking Brake

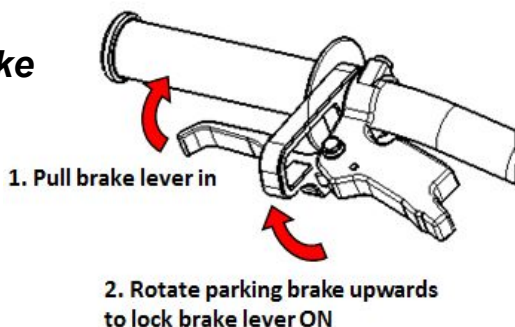

2. Rotate parking brake upwards to lock brake lever ON

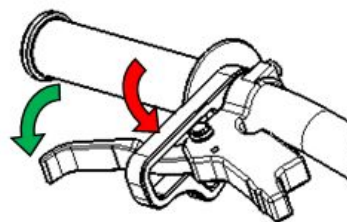

3. Rotate parking brake downwards - brake lever will spring outwards to release the brake

The Pusher must accept full responsibility for control of the MT push and must be capable of controlling the device.

General riding

- **Uphill** - On steep climbs you can use the brakes to prevent roll back between pushes and make the climb easier. Take care to assess the climb and do not tackle slopes that are too steep for the abilities of the Pusher or the MT push.
- **Downhill** - Take care to progress gradually, build confidence and experience flat ground before trying downhill's. Control your speed using the brakes and hold tight to the push handle. Avoid turning sharply across a slope and assess the route ahead for obstacles.
- **Braking** - The brakes are powerful yet controllable, take time to familiarise yourself with the brakes on the flat before attempting slopes. For good control, try dragging the brakes gently rather than grabbing them suddenly.
- **Steering** - Simply move the push handle to the side to initiate a turn. You may find it easier to apply the brake on the wheel on the inside of the turn to make tight turns at low speed. E.g. Apply the Left Brake to help with a tight left turn.

Have a great ride!

If you have any questions, please contact:
info@mountaintrike.co.uk or Tim on 07816 955 945