

ePush Information

A few useful hints and tips to help you get the most out of your MT ePush:



THE ALL TERRAIN WHEELCHAIR

Transfer

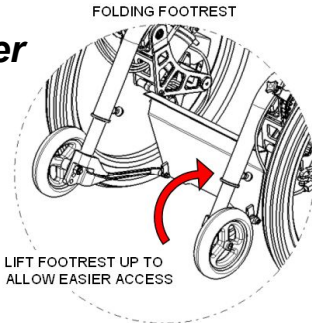

You may wish to move the armrests out of the way by lifting upwards and rotating rearwards

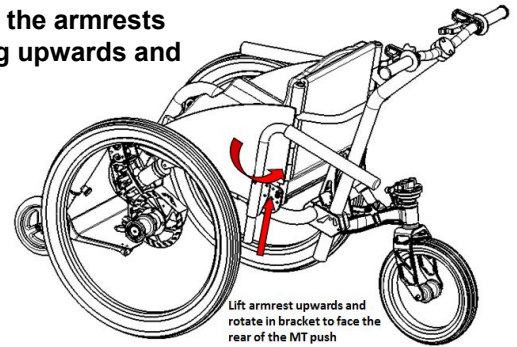

Do not stand on footrest during transfer. Lift the footplate up so it is out of the way, then fold down once seated

Parking Brake

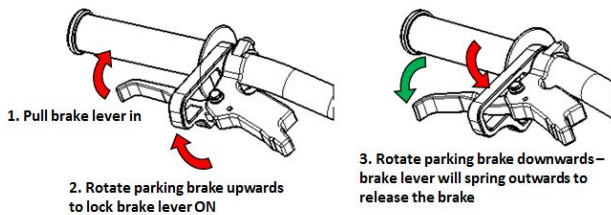

Power Assist



The Pusher must accept full responsibility for control of the ePush and must be capable of controlling the device.

General riding

- **Uphill** - On steep climbs you can use the brakes to prevent roll back between pushes and make the climb easier. Take care to assess the climb and do not tackle slopes that are too steep for the abilities of the Pusher or the ePush.
- **Downhill** - Take care to progress gradually, build confidence and experience on flat ground before trying downhill's. Control your speed using the brakes and hold tight to the push handle. Avoid turning sharply across a slope and assess the route ahead for obstacles.
- **Braking** – The brakes are powerful yet controllable, take time to familiarise yourself with the brakes on the flat before attempting slopes. For good control, try dragging the brakes gently rather than grabbing them suddenly.
- **Steering** – Simply move the push handle to the side to initiate a turn. You may find it easier to apply the brake on the wheel on the inside of the turn to make tight turns at low speed. E.g. Apply the Left Brake to help with a tight left turn.



Have a great ride!

ePush Information

Electric assist controls

Charging - Use the mains charger for charging the battery, this can be done with the battery attached to the ePush or with the battery removed

Battery removal – Ensure battery is switched OFF during removal or fitting. Turn the key and hold while sliding the battery off the mount. To reattach the battery slide the battery in to place whilst turning the key to secure it.

Switching on - first press and hold the rubber button on the battery for 3 seconds until the green lights appear. Then press and hold the centre button on the display to switch on

Power Settings - There are 5 power settings, 1 being lowest and slowest speed, 5 being full power and highest speed. Use the up and down arrow buttons to scroll between the power settings.

Practise - Build up gradually with the ePush. Take time to familiarise yourself with the controls before progressing to using the throttle. Then start on power level 1 and gradually turn the throttle to pull away slowly. The Throttle is sensitive but controllable, so small motions are all that is needed to travel slowly. The quicker you turn the throttle, the quicker you will go.

Slow Turns- It is best to make slow tight turns manually (not using the motor). Turning the throttle too fast on a tight turn can cause the ePush to spin quickly with the risk of tipping over.

Power Assist – It is important to remember that the ePush is a *power assist* Trike. Do not rely solely on the motor. There will be scenarios such as steep climbs, difficult ground and obstacles where it is important to use the push handle in combination with the motor. Also avoid pulling away from a standstill solely using the motor, it is best to use the push handle to assist initial movement under heavy load. This reduces the risk of overstraining the motor or control system.

Throttle control - Do not accelerate too quickly for your abilities or the terrain or situation. Look ahead, make sure you have enough distance to stop or slow down before obstacles and avoid sudden turns at speed. Avoid accelerating with the throttle down a hill.

Do's and Don'ts

Whilst the ePush is aimed all terrain it is wise to avoid submerging the motor or other electrics in water. Shallow puddles and general rain should not be an issue, but deep water is not advised as this would cause damage to the electrics. Do not take the ePush into the sea. Whilst cleaning avoid using too much water on the motor and do not use a pressure washer.

Have a great ride!



THE ALL TERRAIN WHEELCHAIR

